

Model 904 Solenoid Pinch Valve

Acro's Model 904 is a 2-way solenoid pinch valve that is offered in a normally-closed (N/C) default state. This model supports flexible tubing in the 0.125 – 0.250" ($\frac{1}{8}$ – $\frac{1}{4}$ "") outer diameter (OD) range and is configured without an opposing interface to allow customer flexibility in system integration. This model is ideally suited for medical or bioprocessing applications where disposable tubing sets or cassette/cartridges are being used.

Model #	904
Weight	13.8 oz. (392g)
Required Power	7–70 Watts pull-in (pulse) 4–7 Watts hold-in
Tube OD Range	0.125–0.250 in. (3.2–6.4 mm)
Supported Tube Hardness	Up to 70 Durometer Shore A
Mounting Options	Panel
Protective Seals	Panel
Supplied Default State	N/C



Ideal Applications

- Medical Devices: surgical irrigation, dialysis, blood collection, plasma collection, IV and other medical based fluids
- Bioprocessing: media, buffer, antibody, drug dispensing, or general biochemical fluid handling
- Food and Beverage dispensing or transfer
- Industrial filling or dispensing systems
- Water purification, filtration and treatment systems

Features

- Panel mount configuration
- Robust, simple design that supports long cycle life and accommodates larger diameter tubing
- Quiet and smooth operation with minimal heat generation in actuated states
- Splash seal for valve protection and enables easy cleaning without disassembly
- No wetted parts and zero dead volume

Optional Solenoid Valve Accessories

- Solenoid *Pulse and Hold* driver/controller board
- Noise reduction module
- Digital Hall or Optical Sensors
- Custom cabling, ties and harnessing

Ordering and Customization

For ordering information please call 1.925.676.8828 or email us at: info@acroassociates.com

Need a custom pinch valve design? Acro is pleased to offer engineering design services to meet your custom needs. Some modifications often requested are changes to tube slot, pinch ridge, pinch gap, pinch force, occlusion time and alternate material construction.

Engineering Diagram

MECHANICAL

RECOMMENDED TUBING RANGE: .125 - .250 INCH O.D.
[3.2 - 6.4 MM O.D.]

STATE: TUBING NORMALLY CLOSED.
SEALS: PANEL MOUNTING SPLASH SEALS STD.
MOUNTING: PANEL MOUNT IN ANY POSITION.
TUBE LOADING: CASSETTE-STYLE.
NOISE REDUCTION: N/A

ELECTRICAL

VOLTAGE REQUIREMENT: 12 - 48 VDC.
POWER CONSUMPTION:
PULL-IN (PULSE): 7-70 WATTS
HOLD-IN: 4 - 7 WATTS
ACTUATION: PULSE & HOLD CONTROLLER RECOMMENDED.
POSITION SENSING: OPTIONAL, CONSULT FACTORY.
LEADWIRES: 22 AWG UL1061, 3.5" LENGTH

SPECIFICATIONS

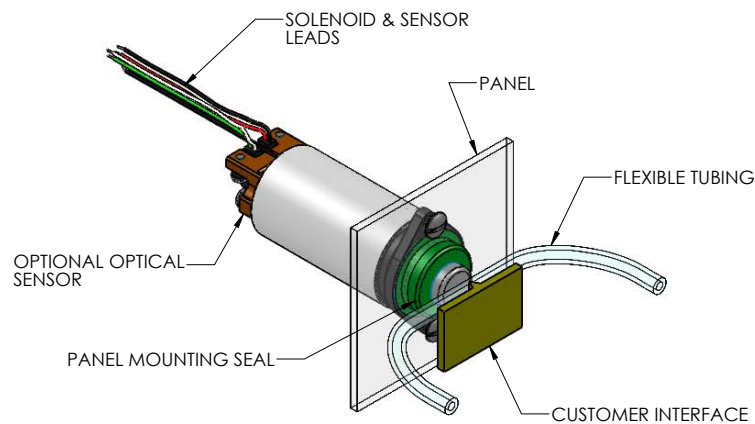

ISOMETRIC VIEW

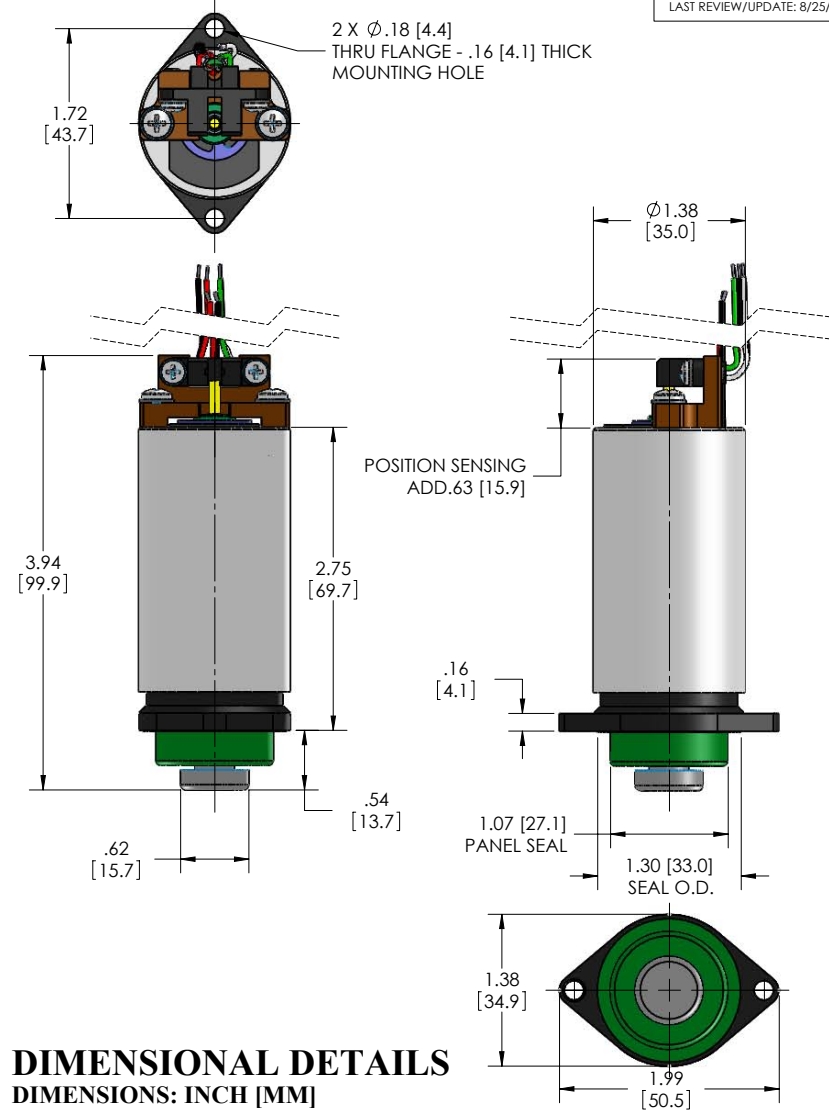

DRAWING NUMBER
D9115

DESCRIPTION
MODEL 904 SOLENOID
PINCH VALVE GENERAL SPECS

THIS DRAWING CONTAINS
INFORMATION PROPRIETARY
TO ACRO ASSOCIATES, INC.

ACRO ASSOCIATES INC
CONCORD, CALIFORNIA



1990 Olivera Road, Suite A
Concord, CA 94520-5455
tel: 925-676-8828 • fax: 925-680-8113
www.acroassociates.com